

## Ultra Precision Shunt Resistor (40 Watts)

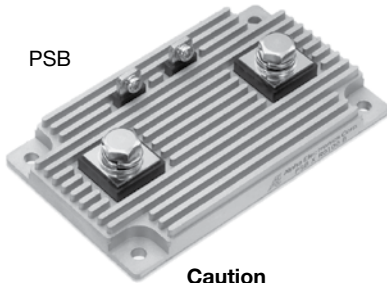

PSB



RoHS COMPLIANT

**Caution**  
Please screw current terminals  
<5N · m, voltage terminal <1N · m

### COMPOSITION OF TYPE NUMBER

Example:

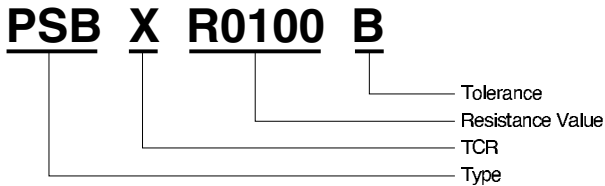

Resistance value in ohm is expressed by a series of four significant digits and an R designating the decimal point.

### CONFIGURATION (DIMENSIONS IN mm)

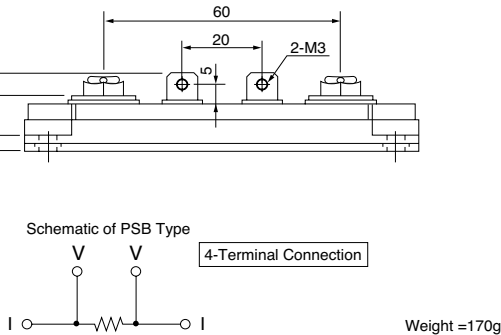
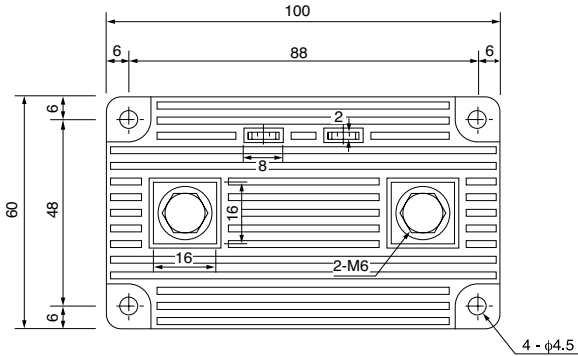

### FEATURES

- Excellent temperature characteristics created by Bulk Metal® foil technology
- Accurate value on four-terminal wiring, even in low extremity of resistance
- High heat dissipation due to aluminum-clad construction with fins
- Readiness to mount to heat sink or water-cooled radiator
- Availability of threaded holes to fix cables with screw

### APPLICATIONS

- Current-sensing in precise power supply, motor driver, etc.

### TCR, RESISTANCE RANGE, TOLERANCE, RATED POWER

TCR (ppm/°C) 0°C to +60°C	Resistance Range (Ω)	Resistance Tolerance (%)	Rated Power (W) at 25°C
0±15 (W)	0.001 to 0.005	±0.1 (B) ±0.5 (D) ±1 (F)	12 in free air and 40 On heat sink*
0±5 (X) 0±15 (W)	0.005 to 1		

\*Thermal resistance of the heat sink 1°C/W.

Available to use higher rated power with elevation of cooling effect.  
Please keep temperature of element surface less than 60°C.

### POWER DERATING CURVE

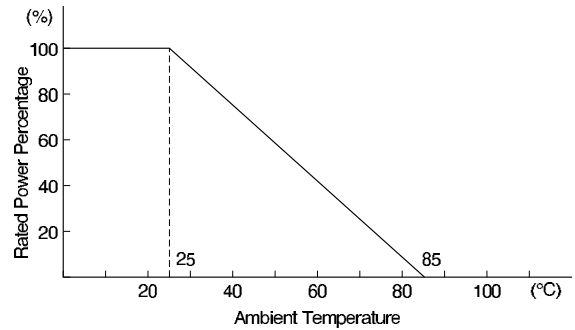

### EXAMPLE OF APPLICATIONS

#### Motor Control Circuit Using Shunt Resistor

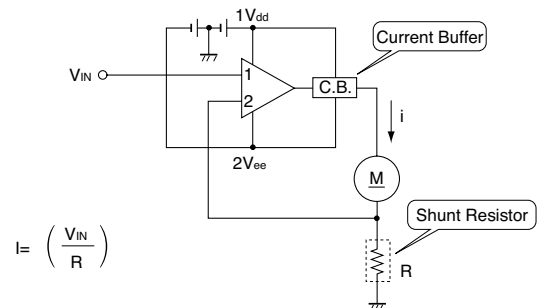

<b>PERFORMANCE</b>			
Parameters	Test Condition	ALPHA Specification	ALPHA Typical Test Data
Maximum Rated Operating Temperature Working Temperature Range Maximum Working Current			25°C -55°C to +85°C 100A
Power Conditioning	25°C, Rated Power, 96 hrs.	±0.1%	±0.05%
Low Temperature Storage and Operation	-55°C, No Load, 24 hrs.	±0.1%	±0.05%
Dielectric Withstanding Voltage Insulation Resistance Low Temperature Operation Overload	Atmo. Pres.: AC 750V, 1 min. DC 500V, 2 min. -55°C, Rated Power Rated Power x 2.5, 5 sec.	±0.05% over 10,000 MΩ ±0.1% ±0.1%	±0.01% over 10,000 MΩ ±0.05% ±0.05%
Moisture Resistance	+65°C to -10°C, 90% RH to 98% RH, Rated Voltage, 10 cycles (240 hrs.)	±0.1%	±0.05%
Shock High Frequency Shock	30G, 11 ms., Half-Sine Wave, X, Y, Z, 10 shocks each 10 Hz to 50 Hz to 10 Hz, 1 min. X, Y, Z, 2.0 hrs. each	±0.05% ±0.05%	±0.1% ±0.1%
Life	25°C, Rated Power, 1.5 hrs. – ON, 0.5 hrs. – OFF, 2,000 hrs.	±0.2%	±0.05%
High Temperature Exposure	85°C, No Load, 2,000 hrs.	±0.2%	±0.05%
Storage Life	15°C to 35°C, 15% RH to 75% RH, No Load, 10,000 hrs.	±0.05%	±0.01%
Internal Thermal Resistance	Between resistive element and base plate		0.3°C/W
Thermal Electromotive Force			1 μV/°C

**FREQUENCY CHARACTERISTICS**

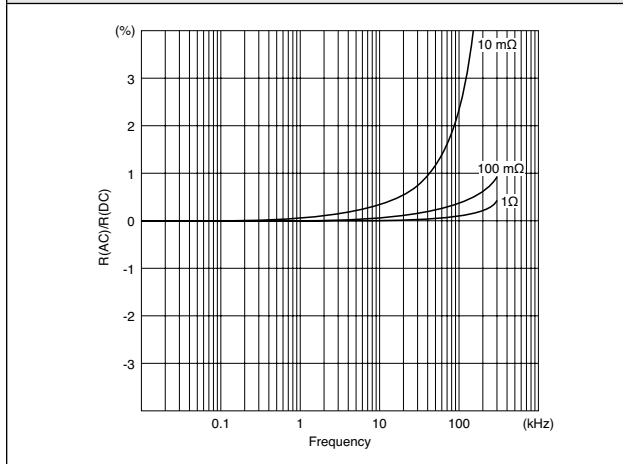

**TEMPERATURE OF RESISTOR SURFACE**

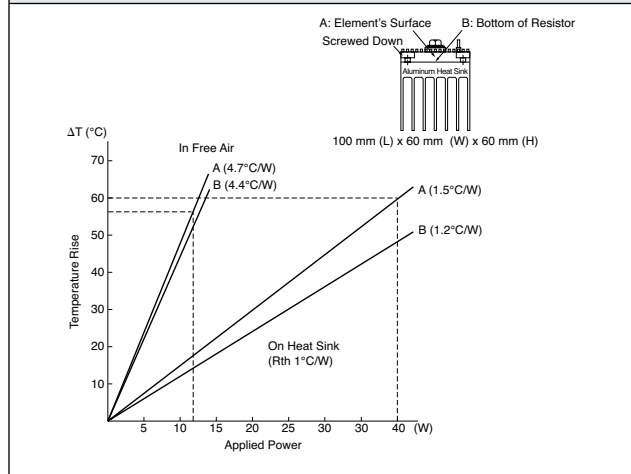



## Disclaimer

ALL PRODUCTS, PRODUCT SPECIFICATIONS AND DATA ARE SUBJECT TO CHANGE WITHOUT NOTICE.

Vishay Precision Group, Inc., its affiliates, agents, and employees, and all persons acting on its or their behalf (collectively, "VPG"), disclaim any and all liability for any errors, inaccuracies or incompleteness contained herein or in any other disclosure relating to any product.

The product specifications do not expand or otherwise modify VPG's terms and conditions of purchase, including but not limited to, the warranty expressed therein.

VPG makes no warranty, representation or guarantee other than as set forth in the terms and conditions of purchase. **To the maximum extent permitted by applicable law, VPG disclaims (i) any and all liability arising out of the application or use of any product, (ii) any and all liability, including without limitation special, consequential or incidental damages, and (iii) any and all implied warranties, including warranties of fitness for particular purpose, non-infringement and merchantability.**

Information provided in datasheets and/or specifications may vary from actual results in different applications and performance may vary over time. Statements regarding the suitability of products for certain types of applications are based on VPG's knowledge of typical requirements that are often placed on VPG products. It is the customer's responsibility to validate that a particular product with the properties described in the product specification is suitable for use in a particular application. You should ensure you have the current version of the relevant information by contacting VPG prior to performing installation or use of the product, such as on our website at [vpgsensors.com](http://vpgsensors.com).

No license, express, implied, or otherwise, to any intellectual property rights is granted by this document, or by any conduct of VPG.

The products shown herein are not designed for use in life-saving or life-sustaining applications unless otherwise expressly indicated. Customers using or selling VPG products not expressly indicated for use in such applications do so entirely at their own risk and agree to fully indemnify VPG for any damages arising or resulting from such use or sale. Please contact authorized VPG personnel to obtain written terms and conditions regarding products designed for such applications.

Product names and markings noted herein may be trademarks of their respective owners.

Copyright Vishay Precision Group, Inc., 2014. All rights reserved.